

KIT VW T4 - VW T4 Lift Roof 98655-111

FIAMMASTORE

- (DE) VERPACKUNGSIHALT
 (EN) PACKAGE CONTENTS
 (FR) CONTENU DE L'EMBALLAGE
 (ES) CONTENIDO DEL EMBALAJE
 (IT) CONTENUTO DELL'IMBALLO

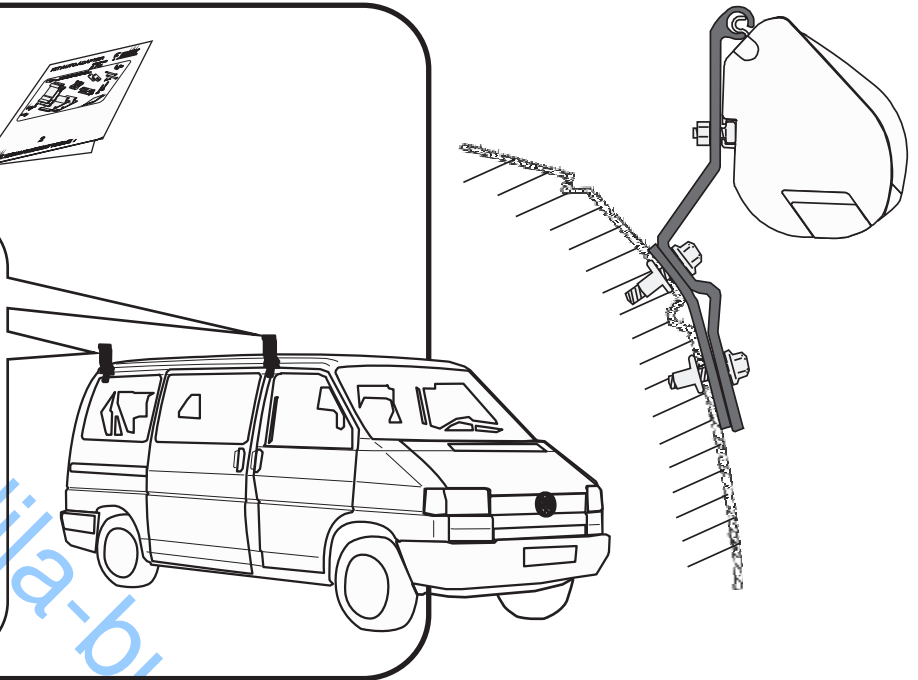
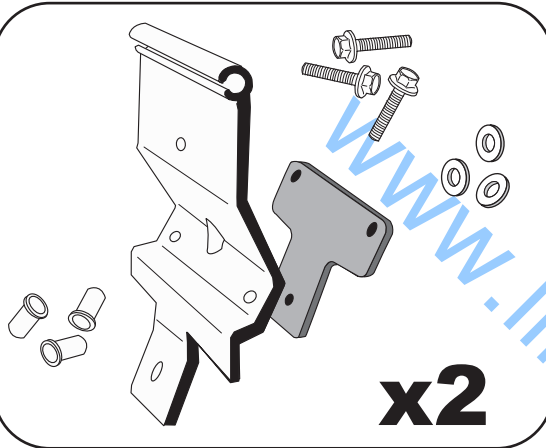
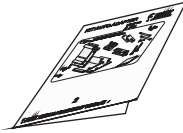

(DE) WICHTIG:
 BITTE VERGEWISSEN SIE SICH
 BEIN ANBRINGEN DER HALTER-
 UNGEN DASS SICH DIESE AUF
 DERSELBEN LINIE BEFINDEN.

(EN) IMPORTANT:
 WHEN INSTALLING THE BRACKETS,
 MAKE SURE THAT THEY ARE
 ALIGNED.

(FR) IMPORTANT:
 LORS DU MONTAGE, S'ASSURER
 QUE LES PATTES SOIENT BIEN
 ALIGNEES ENTRE ELLES.

(ES) IMPORTANTE:
 CUANDO SE MONTAN LOS
 ESTRIBOS, ASEGURARSE QUE
 SEAN ALINEADOS.

(IT) IMPORTANTE:
 NEL MONTARE LE STAFFE
 ASSICURARSI CHE SIANO BEN
 ALLINEATE TRA LORO.

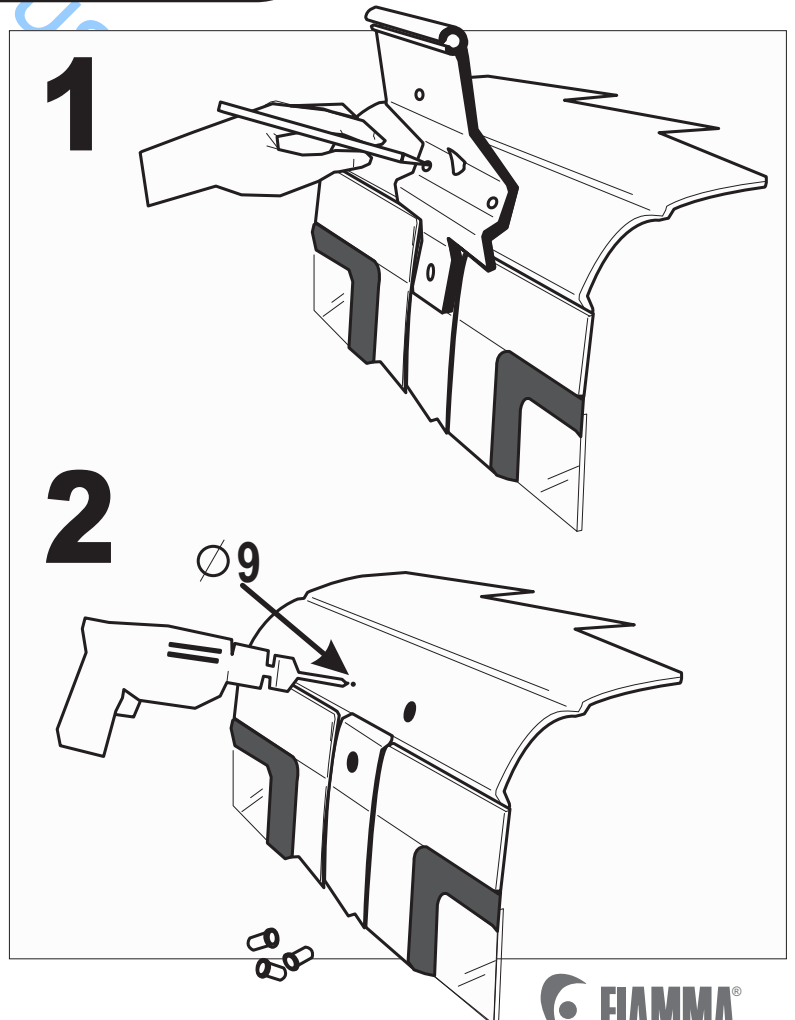

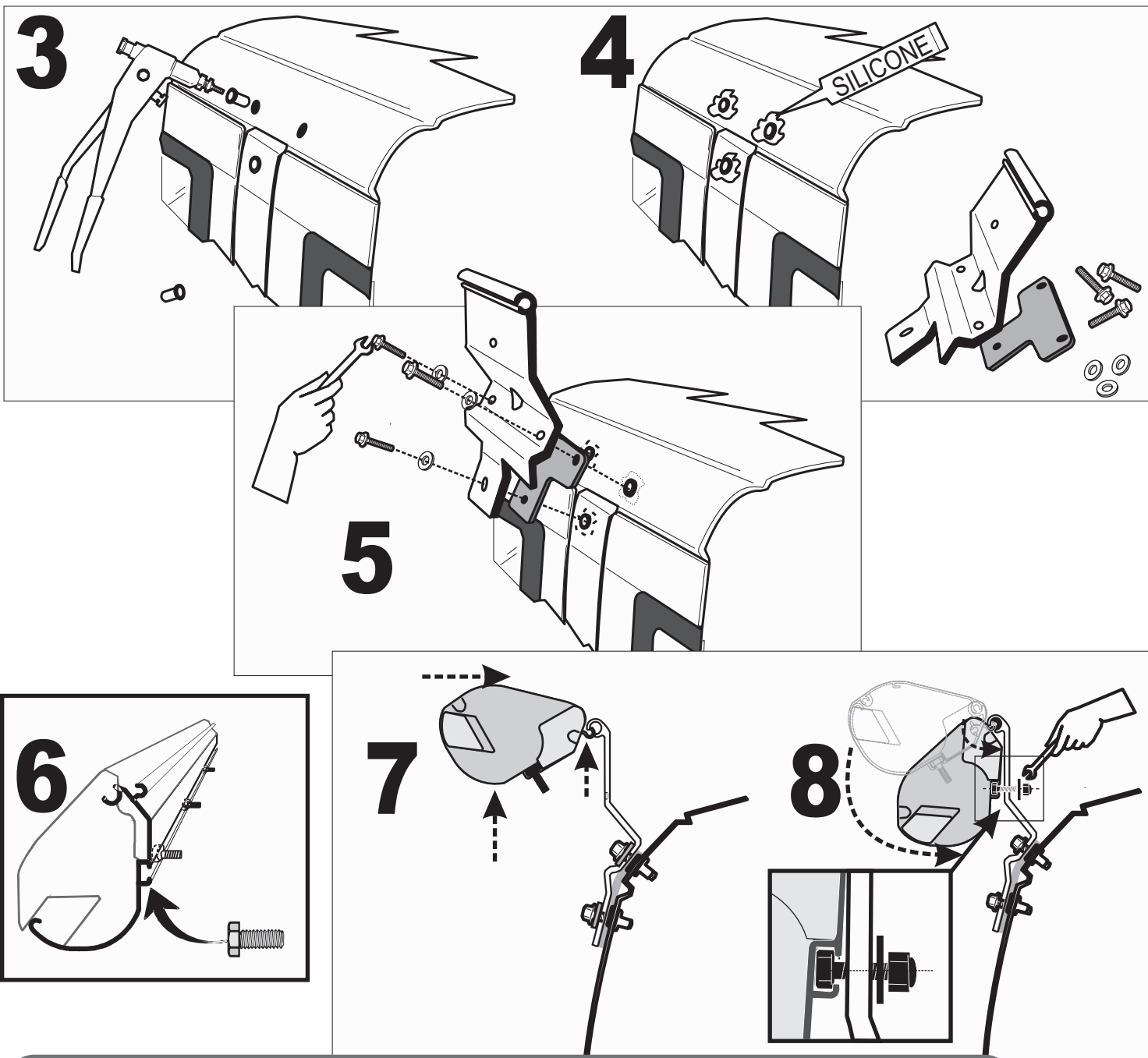

ACHTUNG Regelmäßig die Befestigung der Halterungen kontrollieren. Achten Sie vor allem nach dem ersten Sicherstellen darauf, dass sich die Haltebügel nicht verschoben haben.

(EN) ATTENTION Periodically check the brackets to make sure it is firmly attached (especially after the first kilometers) make sure the belts are not loose and that holding brackets have not shifted.

(FR) ATTENTION Contrôler périodiquement l'état de fixation des pattes (surtout après les premiers kilomètres) en s'assurant que les supports de fixation n'aient pas bougé.

(ES) CUIDADO Controlar periódicamente el estado de fijación de los estribos (sobretudo después de los primeros Kms) asegurándose que no se desplacen.

(IT) ATTENZIONE Controllare periodicamente lo stato di fissaggio delle staffe (soprattutto dopo i primi chilometri) assicurandosi che le stesse non si siano mosse e che i serraggi siano corretti.



(DE) Bitte halten Sie sich beim Gebrauch der Markise an die Gebrauchsanweisung.

(EN) When using the awning please follow the instructions of the product.

(FR) Pour l'utilisation du store, se référer aux instructions du store même.

(ES) Para el uso del toldo, atenerse a las instrucciones que se encuentran en el producto.

(IT) Per l'utilizzo del tendalino, attenersi alle istruzioni presenti nel prodotto.



All rights reserved. Fiamma S.p.A. reserves the right to modify at any time, without notice, prices, materials, specifications and models or to cease production of any model.

FIAMMASTOR 05 2012

MADE IN ITALY